

# Installation Instructions

## Hilltip 100 - Tailgate Spreader

### Safety Precautions

#### WARNING

Observe the following Safety Precautions before, during and after operating this spreader. By following these precautions and common sense, possible injury to persons and potential damage to this machine may be avoided.

1. Read this entire Installation Instruction before operating this spreader.
2. Read all safety decals on the spreader before operating.
3. Verify that all personnel are clear of the spreader spray area before starting or operating this spreader.
4. Do not adjust, clean, lubricate or unclog material jams without first turning off the spreader.
5. Make sure the spreader is securely fastened to the vehicle in accordance with this manual.
6. Do not operate a spreader that is in need of maintenance or repairs.
7. Always disconnect the battery before removing or replacing electrical components.

### Materials Recommended to Spread

- Pelletized Ice Melt
- Bagged Rock Salt, Dry Free flowing

### Average Installation Time

- 1-2 hours



#### SPREADER WARRANTY

This warranty replaces all previous warranties and no employee of this company is authorized to extend additional warranties, or agreements, or implications not explicitly covered herein.

Oy Hilltip Ab warrants all parts of the product to be free from defects in material and workmanship for a period of one (1) year. Parts must be properly installed and used under normal conditions. Normal wear is excluded.

Any part, which has been altered, including modifications, misuse, accident, or lack of maintenance will not be considered under this warranty.

The sole responsibility of Oy Hilltip Ab under this warranty is limited to repairing or replacing any part(s), which are returned, prepaid, 30 days after such defect is discovered, and returned part(s) are found to be defective by Hilltip. Authorization from Oy Hilltip Ab must be obtained before returning any part. The following information must accompany defective parts returned to Hilltip: RMA #, spreader model, serial number, date installed, and distributor from whom purchased.

Oy Hilltip Ab shall not be liable for damage arising out of failure of any unit to operate properly, or failure, or delay in work, or for any consequential damages. No charges for transportation or labor performed on any part will be allowed under this warranty.



## Spreader Assembly

Check contents of box against parts list to make sure all components are included. When ordering replacement or spare parts refer to parts list for part numbers.

1. Insert frame #3024170 into hitch receiver. (Fig.1)

Fig. 1

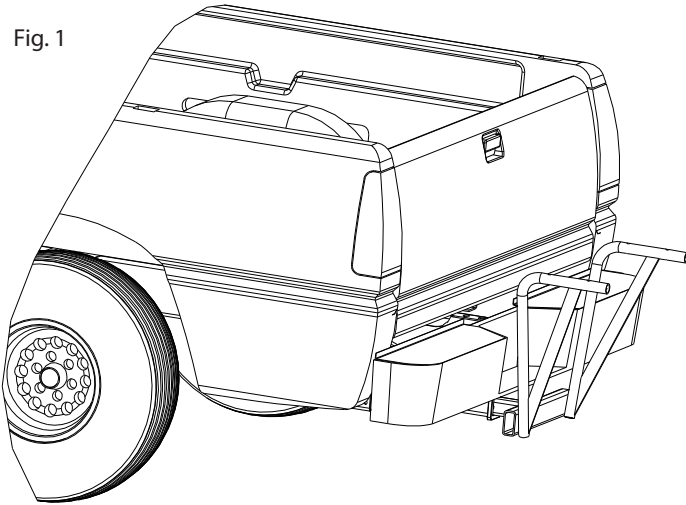

2. Insert round plugs into frame tubes.  
Lower hopper assembly onto frame tubes. Align holes in hopper with holes in frame. Secure hopper to frame using 1/4 screws, washers and nuts as shown. (Fig.2)

Fig. 2

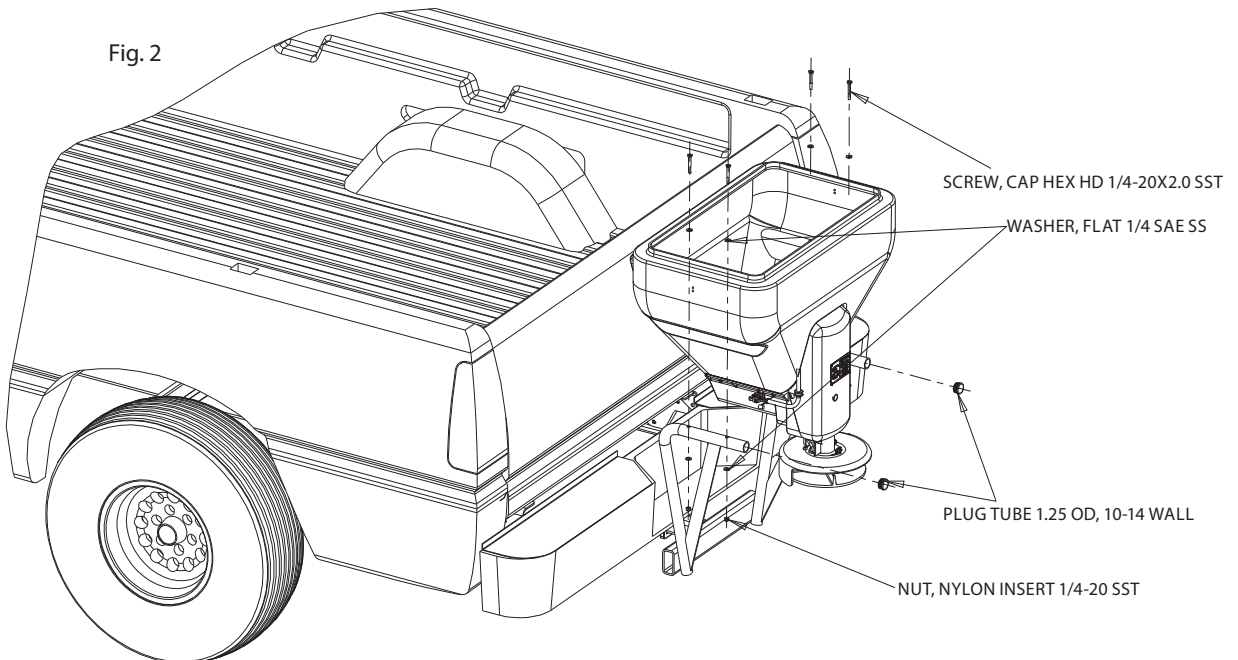

3. Align holes in frame and hitch receiver. Secure frame in hitch receiver using 5/8" hitch pin and cotter pin. (Fig.3)

Fig. 3

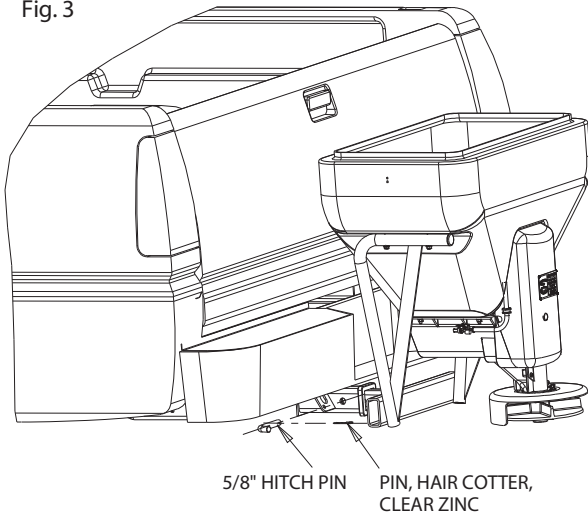

4. Assembly catchers to hopper using #10 button head screws. (Fig.4)

Fig. 4

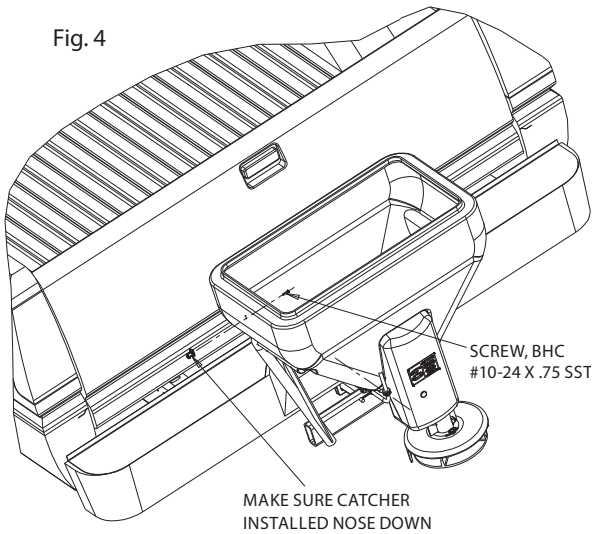

5. Assembly brackets and rubber handles to lid using #10 button head screws. (Fig.5)

Fig. 5

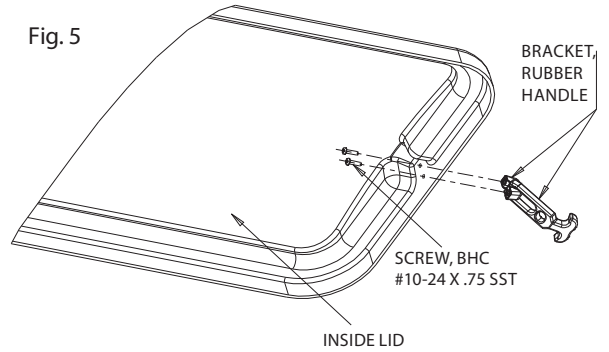

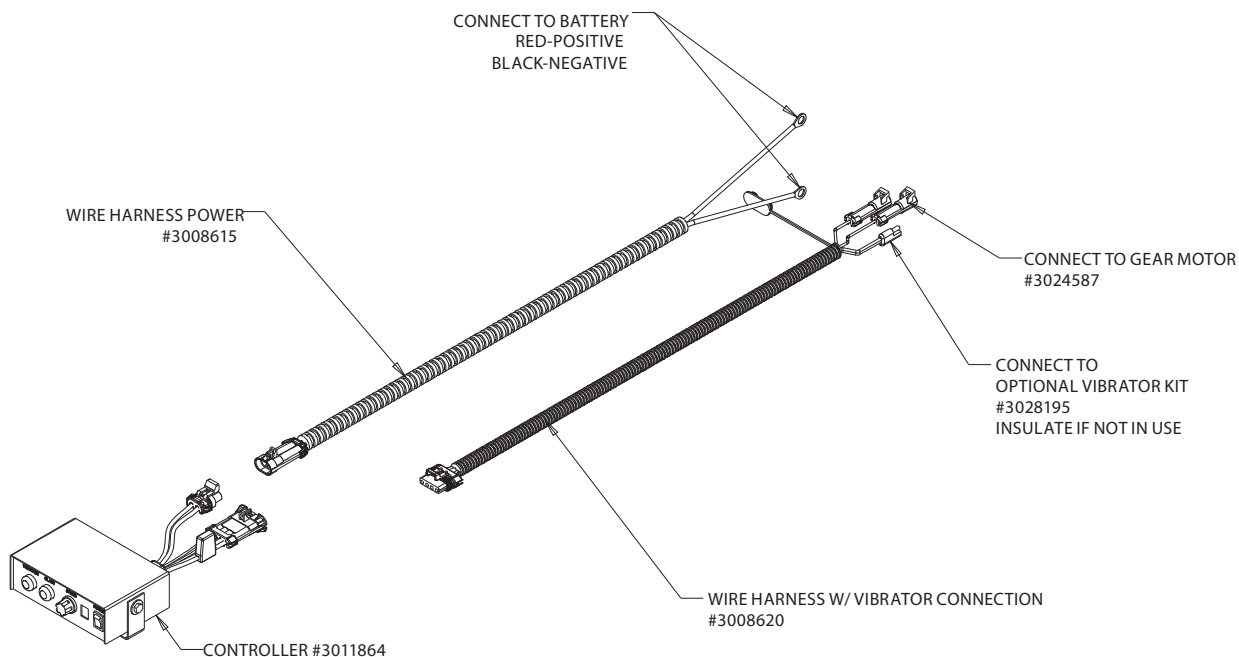

## Installing Controller and Wiring

**THIS IS WIRE GROUND ELECTRICAL SYSTEM!  
NO CONNECTIONS TO TRUCK'S FRAME OR BODY  
ALLOWED!**

To insure good performance of your spreader, check the condition of truck's electrical system. Using digital voltmeter, check alternator and battery voltage. The voltage reading should fall between 13.6 and 15.3 volts with engine running, head lights and heater fan turned on. If voltage reading falls out of this range, check and adjust your electric system.

NOTE: Always disconnect battery before attempting to install electrical components on your vehicle. Mount the controller in a convenient location in the truck cab. It is recommended not to mount the controller directly in front of heat vents. Allow ample air space around controller.



### CAUTION

**DO NOT MOUNT CONTROLLER IN THE WAY OF AIR BAG DEPLOYMENT!**

1. Route both wire harnesses into truck cab through firewall (it maybe necessary to drill holes). Insulate hole to avoid water leaks.

2. Insure no wires are nicked or damaged during installation.
3. Connect the 4-pin connector on the wire harness to the control box.
4. Connect the 2-pin connector on the power cable to the control box.
5. Lay out a path for the power cable to the battery, use quick ties to secure power cable.  
**DO NOT CONNECT TO BATTERY AT THIS TIME!**
6. Lay out path for wire harness to the rear of the vehicle. It is recommended to stay clear of the exhaust system. Excess heat can damage the wire harnesses. Use quick ties to secure harness to underbody.
7. Connect the wire harness to the gear motor.
8. Connect the power and ground wires directly to the battery (Red - Positive, Black - Negative)  
NOTE: Thoroughly clean battery terminals. Make sure battery terminals have no tarnish or corrosion. Do Not Connect Wire Harness To Damaged Or Corroded Terminals! It May Result In Overheating, Lost Power And Potential Controller Damage!
9. Insure all functions of the controller are working properly.  
NOTE: direction of spinner may be changed by interchanging the motor leads.

## Spreader Operation.

1. Due to the rate at which materials absorb moisture differently, some materials may not perform as desired. Therefore, the substitution of an alternative material may be necessary for optimum performance.
2. When filling hopper use only screened material. Prevent large chunks of material and debris from getting into hopper and cause operational problem or damage.
3. Material must never be left in the hopper for extended period of time. Material will absorb moisture, bind, harden and may prevent spreader from proper operation or may damage the spreader.
4. To start spreader make sure that truck engine is running. Flip POWER switch in ON position. Switch will illuminate. Spreader motor will accelerate to full speed and then it will slow down to previously dialed speed.
5. To adjust material flow rate and spreading distance, simply rotate speed knob to desired speed. Spreader can be put in full speed mode for short time by pressing and holding BLAST button.
6. To activate and deactivate vibrator (optional) press VIBRATOR button, if equipped.
7. Material flow and pattern can be adjusted by opening/ close adjustable discharge on the trough bottom. (Fig.6)

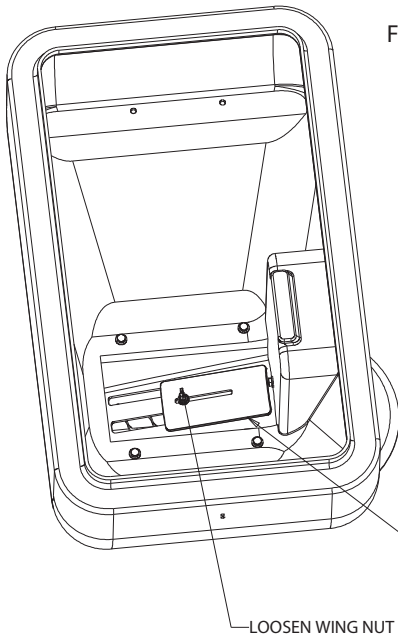

Fig. 6

SLIDE FEED GATE  
TO DESIRED LOCATION.  
RETIGHTEN WING NUT

LOOSEN WING NUT

## Optional Vibrator Installation.

Even if material stored in bags, it can still absorb moisture thru microscopic holes in plastic bags. Thus some materials may have high moisture content right from the bag. This condition may prevent material free flowing and may easily clog spreader. In order to improve material flow, install optional vibrator kit #3028195. Follow supplied installation instructions.

## Controller Warnings.

Check controller instruction sheet for latest controller updates, troubleshooting codes. Controller instruction sheet is inside controller shipping box.

**IMPORTANT! INSTALLER, DO NOT DISCARD CONTROLLER INSTRUCTION SHEET. STAPLE SHEET TO SPREADER MANUAL AND GIVE TO END USER!**

## Maintenance Instructions.

1. Wash spreader after every use. Make sure no material left under auger and/or inside trough.
2. Inspect and retighten fasteners after every 5-7 hours of operation.
3. Inspect terminals/ connectors every time you disconnect spreader from wire harness. Apply thin layer of dielectric grease on terminals. If any tarnish/corrosion found, clean terminals and apply dielectric grease.

## End of Season Maintenance.

1. Wash spreader. Make sure no material or residue left in and outside hopper.
2. Inspect wire harness, connectors for broken insulation, missing components. Replace if necessary.
3. Apply dielectric grease on all electrical connectors.
4. Store hopper indoors, in dry, cool place.
5. Inspect, clean and repaint frame.
6. Remove controller from truck. Store controller indoors, in dry, cool place.

## Hopper Assembly

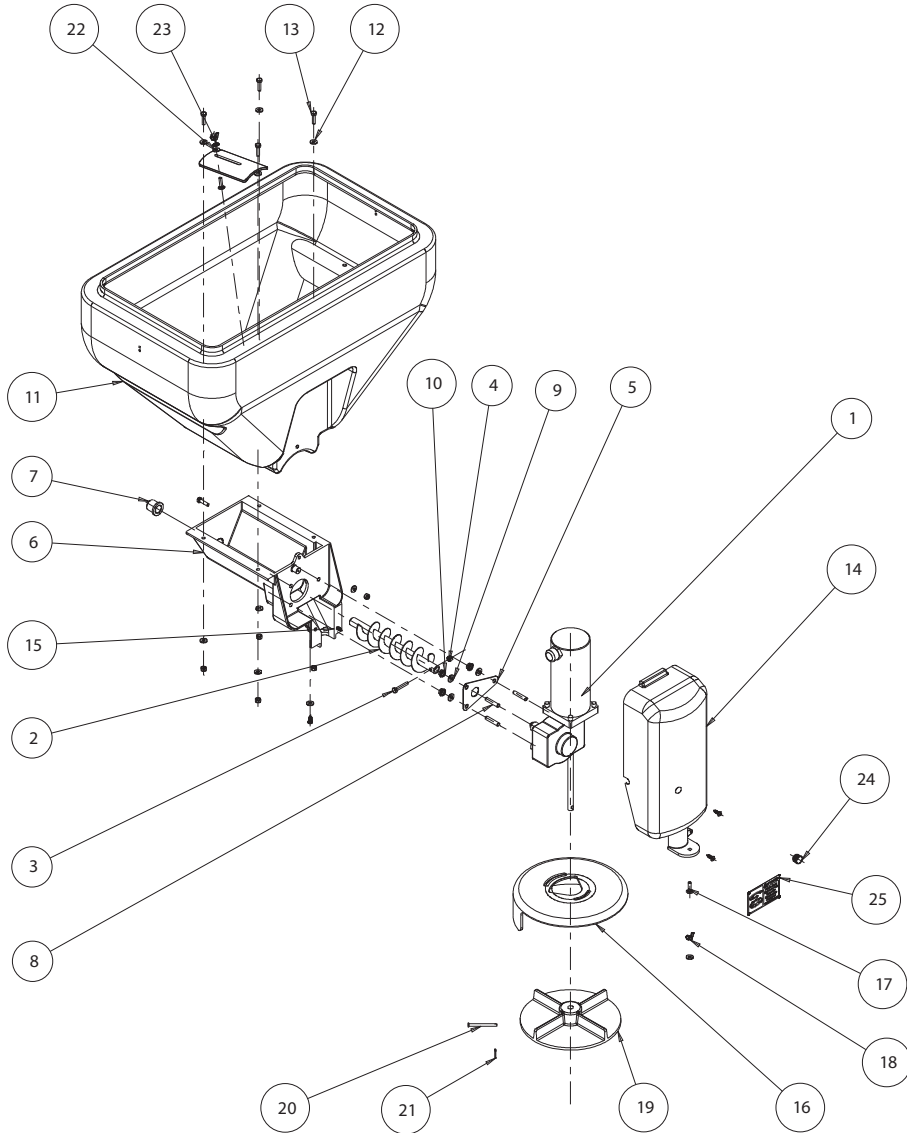

### Bill of Materials

ITEM	PART NO.	QTY.	DESCRIPTION
1	3024587	1	GEAR MOTOR 12 VDC. DUAL SHAFT
2	3024588	1	AUGER
3	FCS025020150SS	1	SCREW, HHC - 1/4-20 X 1-1/2 SS
4	FNE025020031SS	6	NUT, NYLON INSERT 1/4-20 SST
5	3024591	1	RETAINER GEARMOTOR, CHUTE
6	3026097	1	TROUGH Spreader Model 100
7	3024590	1	SLEEVE BEARING .75 ID FLANGED
8	3027511	3	STUD THREADED 5/16-18 X 1.5 SST
9	FWF031075006SS	3	WASHER, 5/16 SAE SST
10	3006719	3	NUT, HEX FLANGE - 5/16-18 SS
11	3026096	1	HOPPER Spreader Model 100
12	FWF025063007SS	13	WASHER, FLAT 1/4 SAE SS
13	FCS025020100SS	5	SCREW, CAP HEX HD 1/4-20 X 1 SST

ITEM	PART NO.	QTY.	DESCRIPTION
14	3026098	1	COVER, GEAR MOTOR
15	3026118	4	SCREW, SHT MET #12x 3/4 SST
16	3024168	1	SHIELD
17	FCB025020100SS	2	BOLT, CARRIAGE, 1/4-20 X 1 SST
18	3016751	2	NUT, WING 1/4-20 SST
19	3010970	1	SPINNER, POLY, TGS06
20	1420014	1	PIN CLEVIS, 1/4 X 2.5
21	FPC007800075	1	COTTER PIN, 5/64 X 3/4
22	3024180	1	FLOW GATE
23	3023463	1	WASHER, LOCK, 1/4in, SST, EXT
24	3027662	1	PLUG ROUND TUBE 3/4-14-20 WALL
25	3027608	1	DECAL, CORRECT ROTATION

## Spreader Assembly

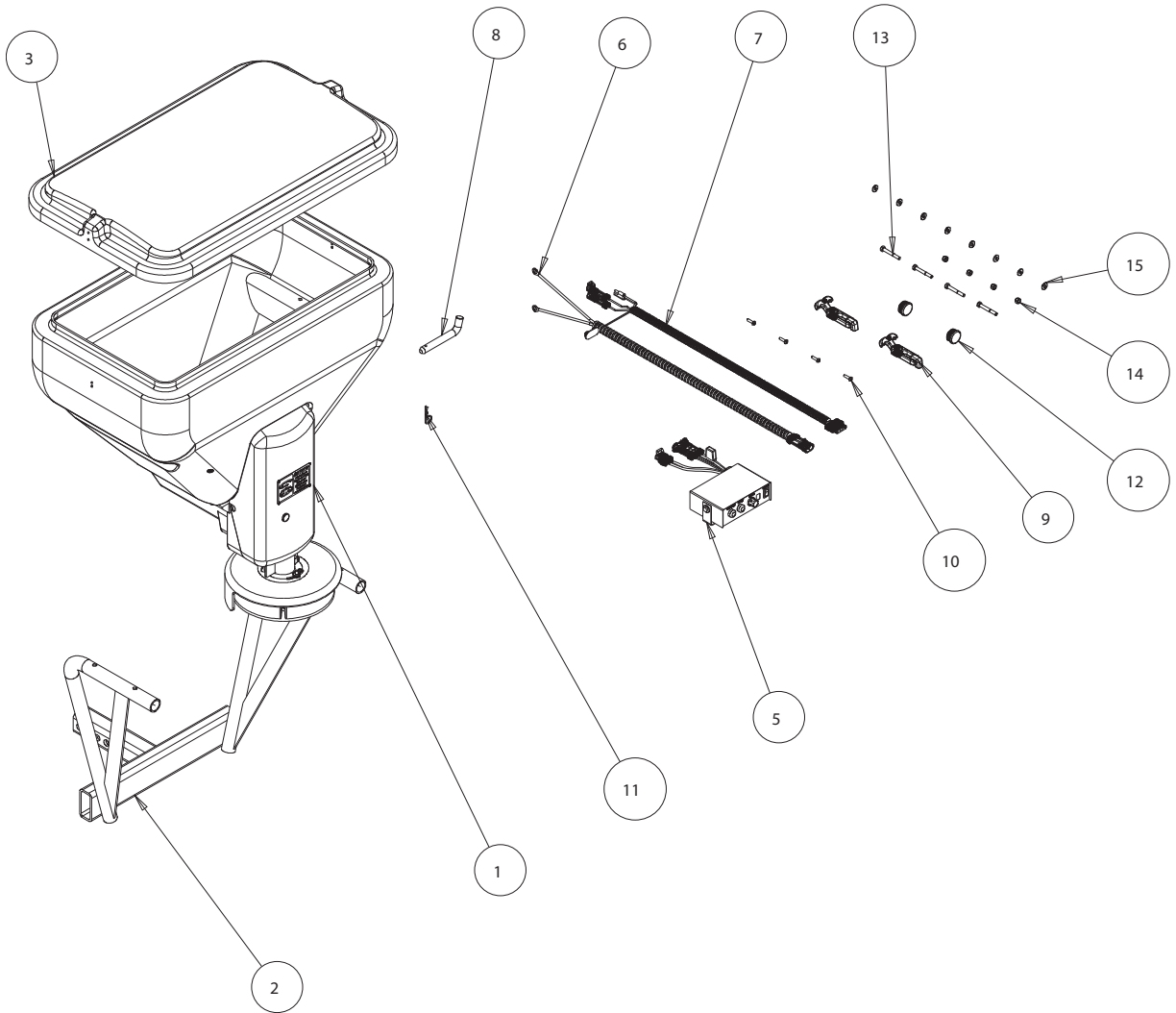

### Bill of Materials

ITEM	PART NO.	QTY.	DESCRIPTION
1	3026099	1	HOPPER ASSEMBLY Spreader Model 100
2	3024170	1	FRAME WELDMENT
3	3024593	1	LID
4	3024167	1	HARDWARE BAG Spreader Model 100
5	3011864	1	CONTROLLER TGS W/ VIBRATOR SWITCH
6	3008615	1	WIRE HARNESS, POWER TGS
7	3008620	1	WIRE HARNESS MAIN W/ VIBRATOR, TGS
8	HP6253WC1	1	PIN, 5/8 HITCH
9	WJ215	2	LATCH DRAW RUBBER
10	FBSH01002475SS	4	SCREW, BHC #10-24 X .75 SST
11	1420016	1	PIN, HAIR COTTER, CLEAR ZINC
12	3026613	2	PLUG TUBE 1.25 OD, 10-14 WALL
13	3017932	4	SCREW, CAP HEX HD 1/4-20X2.0 SST
14	FNE025020031SS	4	NUT, NYLON INSERT 1/4-20 SST
15	FWF025063007SS	8	WASHER, FLAT 1/4 SAE SS



Pukkisaarentie 6 • 68600 Pietarsaari • Finland  
www.hilltip.com • info@hilltip.com



**Oy HillTip Ab**  
Pukkisaarentie 6  
FIN-68600 Pietarsaari  
Finland

**Phone:** +358505983026  
**Phone:** +358503659415  
**Fax:** +358 (0) 6 724 36 06

www.hilltip.com  
info@hilltip.com

---



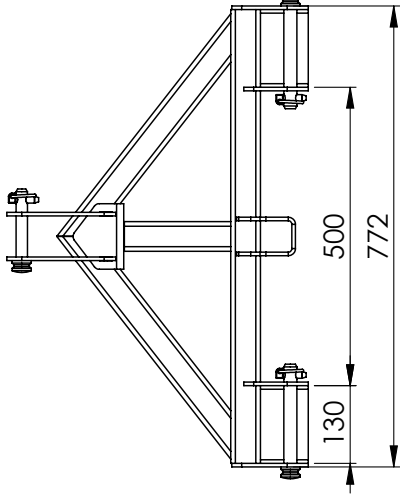
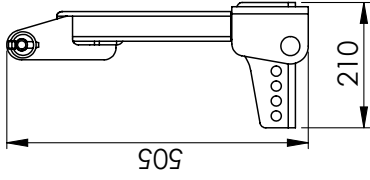
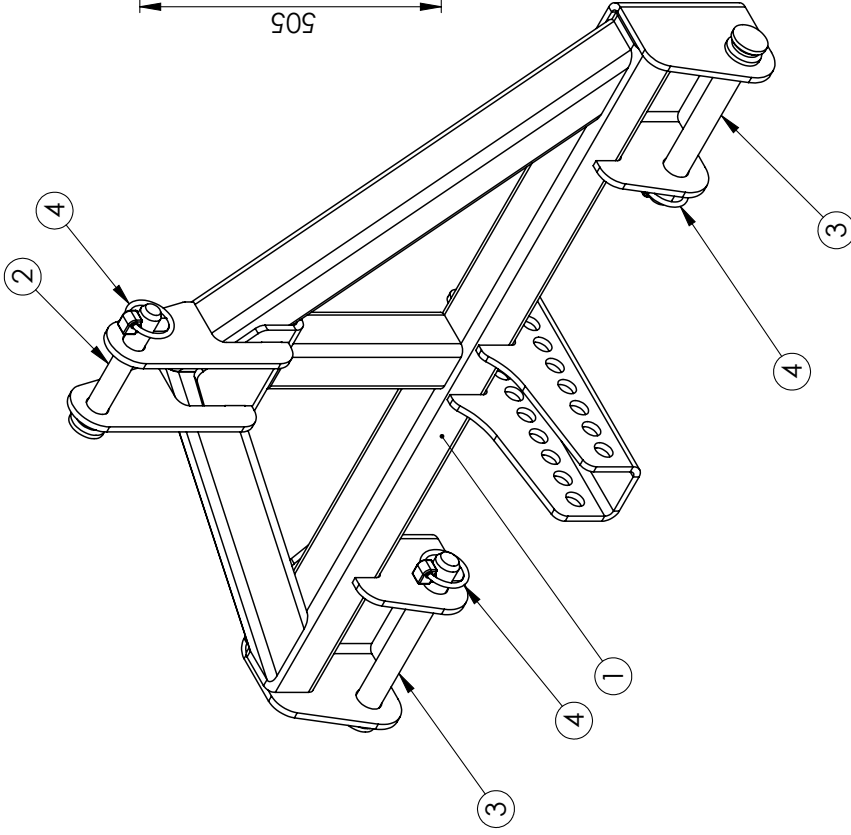

4	H22113	-	Locking pin	-	Locking pin	IKH T0433
3	H21262	-	Pin 22x190	-	Pin 22x190	
2	H21208	-	Pin 19x102	-	Pin 19x102	IKH V1023/35
1	H23057	1	Frame	revision	desc1	
Item	Qty	item				
			Finishing		NOTE	
			Size	Drawn by	Modified by	Approved by
			A4	Cfo	Cfo	
			Page	Date	Date	Date
			1(1)	09.09.2014	08.10.2014	
			Weight [Kg]	Scale		Revision
			17.5	1:10	H23056	1
			Product	Drawing no		
			Kit	H23056		
			3-point hitch, Tractor 100L			
						
			Oy Hilltip Ab Kangasitie 9 FI-68600 PIETARSAARI			

ALL NON TOLERANCED PARTS TO BE ACCORDING TO ISO 13920-B / ISO 2768-m